



RETALT: Recovery GNC for the Retro-Propulsive Vertical Landing of an Orbital Launch Vehicle

P. Ghignoni¹, A. Botelho¹, C. Recupero¹, V. Fernandez¹, A. Fabrizi¹, G. De Zaiacomo¹

Abstract

This paper presents the RETALT recovery mission GNC, with a focus on the GNC solutions for the powered descent and landing phase. RETALT is a European Union Horizon 2020 project with the objective of investigating launch system reusability technologies for different classes of vertical take-off vertical-landing vehicles. Launcher reusability is the most effective way of reducing access to space available, but remains a great technical challenge for the European aerospace industry, which lags largely behind its US counterparts. One of the challenges lies in the recovery GNC strategy and algorithms, in particular those of the powered-landing phase, which must enable a precise landing with low fuel-margins and significant dispersions. To tackle this, state-of-the art algorithms based on hybrid Navigation techniques for state estimation, as well as online convex optimization and successive convexification for the design of the guidance GNC sub-function are explored. The proposed GNC solutions were integrated and tested in a high-fidelity simulator and the performance were preliminary assessed.

Keywords: Powered Landing, Recovery, GNC, Optimisation, RETALT

1. Introduction

Launch vehicle reusability is currently the most effective way of reducing the cost of access to space, which is a key endeavour to the commercialization of space. Despite this, it remains a great technical challenge, with only two US entities (companies SpaceX and Blue Origin) having developed the necessary technology to carry out routinely successful recovery missions, both using retro-propulsive vertical landing as the recovery strategy, and both reporting significant cost savings due to the reusability effort. On the other hand, the European aerospace industry remains largely behind in this effort, risking being far outcompeted if it does not catch up with its US counterparts.

In this context, the EU and ESA have made increasing efforts to achieve the goal of making launcher reusability the state-of-the-art in Europe. One such effort is RETALT (Retro Propulsion Assisted Landing Technologies) [1], a Horizon 2020 project with six partners in four European countries, with the goal of investigating launch system re-usability technology for two classes of launch vehicles with retro-propulsive recovery: RETALT1, a two-stage to orbit (TSTO) launcher, similar to SpaceX's Falcon 9; RETALT 2, single-stage to orbit (SSTO), similar to the DC-X. For the former, only first stage recovery is performed. The project aims to increase the Technology Readiness Level (TRL) of the recovery technologies up to 5 for structures and mechanisms, and up to TRL 3 for GNC.

One of the great technical challenges in this endeavour lies in the recovery Guidance, Navigation and Control (GNC) system, of which DEIMOS Space is in charge for RETALT. In particular, the design of the powered-descent and landing GNC offers a difficult challenge, since it must allow the system to perform

¹DEIMOS Space S.L.U., Ronda de Poniente 19, Tres Cantos, 28760, Spain, gabriele.dezaiacomo@deimos-space.com

a precision landing in a fast-dynamic environment, with extremely limited fuel margins, and with significant unknown dispersions accumulated during prior phases. Therefore, this phase is the focus of the present paper. The aimed TRL for the RETALT recovery GNC is 3, meaning that the proof-of-concept is to be demonstrated analytically or experimentally in a realistic simulation environment.

Although autonomous powered-landing GNC strategies and algorithms have been available from past Moon and Mars robotic landing missions, these may not be suitable to tackle the additional difficulties of the present mission. These include a higher Earth gravity and hence faster dynamics, a non-negligible atmosphere, and minimal fuel available due to the recovery not being the primary mission. In particular, the guidance GNC sub-function for the present design must employ state-of-the-art algorithms based on online optimal control optimization, which allows for generating feasible and fuel-optimal reference trajectories in real-time.

2. Reference mission and configuration

The baseline configuration and the main focus of the project and this paper, is RETALT 1. The vehicle operates similarly to a typical launcher until separation, after which two scenarios for the first stage recovery are considered: Downrange Landing (DRL) and Return to Launch Site (RTLS). The latter differs in the use of a post-separation flip manoeuvre and boost-back burn that modifies the ballistic arc to allow a landing at or near the launch site, while the former foresees a landing at sea on a floating barge. Both scenarios employ a re-entry burn, in order to reduce velocity (from hypersonic to high supersonic speed) and dispersions, and an active aerodynamic descent phase enabled by the use of control surfaces. Finally, the first stage recovery mission ends with an engine-powered descent and

pinpoint vertical landing, which slows the vehicle down from low supersonic/transonic velocity to a soft touchdown.

The concept configuration of the RETALT1 first stage was designed assuming the use of Vulcain-like engines [1], and has a dry mass of 59.3 tons and 57 tons of propellant available for the return manoeuvres (50 tons plus 7 reserve). Different configurations were studied for the RETALT1 concept, including interstage petals (IS), planar fins (PF), and grid fins (GF), with the planar fins configuration eventually selected as the baseline, used as the reference configuration for the design of the GNC concept.

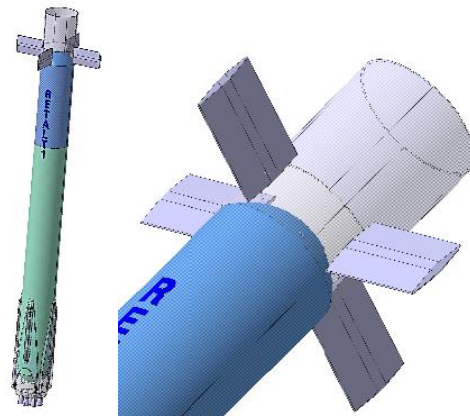

Figure 1: Baseline RETALT1 concept, with planar fins as main aerodynamic actuators

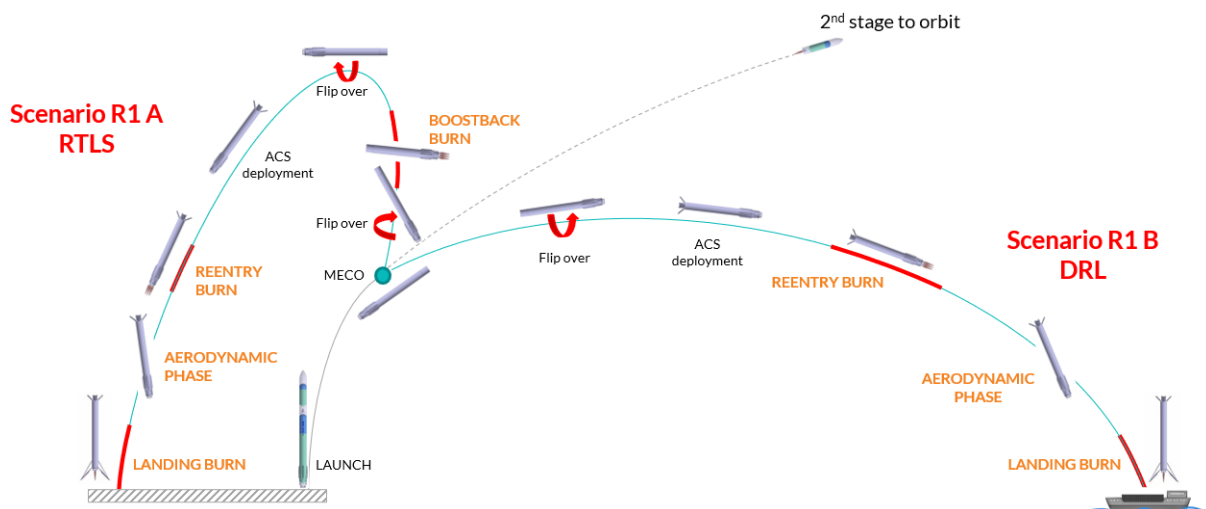

Figure 2: RETALT 1 return mission concept

3. Recovery GNC design

3.1. Functional Architecture

The diagram in Figure 3 represents the functional architecture of the GNC solution for the RETALT1 return mission.

The GNC is split into the following sub-functions:

- **Navigation:** estimates the current state of the system. The navigation solution is served primarily by the Inertial Measurement Unit (IMU or INS - Inertial Navigation System -), which is hybridized with a (D)GNSS receiver, and could also make use of other sensors (e.g. (F)ADS, altimeter), if available, depending on the mission phase, even if they are not strictly required.
- **Guidance:** consists of a guidance algorithm whose aim is to define the re-entry trajectory during the return phase. This serves to ensure the vehicle is able to perform a pinpoint landing, respecting the mission and flight path constraints.
- **Control:** the control algorithm may operate in distinct modes dependent on the GNC phase and available GNC actuators. In general, the control tracks the guidance trajectory and ensures a stable attitude, using the effective actuators for the phase. This includes the actuator management.

The Control and Navigation functions interact with the actuators and sensors. The FM function collects status information and data from each of the GNC's system main functions and further sends them to the MVM, which based on the information received from Ground and from the other vehicle subsystems, sends back updated information to the FM function. As mentioned above, the FM function uses the updated data in order to define the appropriate functional mode for each of the Guidance, Navigation, and Control functions. The design and development of the GNC solution focused on the Guidance, Navigation, and Control algorithms. The FM and MVM algorithms are simple mode selector algorithms.

The GNC operational modes are defined by the mission phase in Table 1, together with the sensors and actuators applicable for each mode. The Guidance commands the attitude manoeuvres required in each phase of the flight, the modulation of the attitude during the re-entry burn and the aerodynamic phase to target the correct location at the start of the landing burn. The Control takes care of executing these manoeuvres while rejecting perturbations, making use of Thrust Vectoring Control (TVC), Reaction Control System (RCS), and Aerodynamic Control Surfaces (ACS) based on their availability during the flight. The main difference between the RTLS and the DRL scenarios is that the latter lacks the quick flip over manoeuvre and the boost-back burn, while the other modes are exactly the same, even if the trajectory conditions are slightly different (in particular, the RTLS requires a shorter re-entry burn as the boost-back burn contributes limiting the aerothermodynamic loads during the descent).

Table 1: RETALT1 recovery GNC modes

Phase	Guidance	Navigation	Control	Maneuvers
Boostback burn	Landing site targeting	Hybrid IMU/INS – (D)GNSS	Maneuvering, Pert. Rejection TVC / RCS	Quick Flip over Boostback burn
High altitude ballistic flight	-		Maneuvering, Pert. rejection RCS	Slow Flip over ACS deployment
Reentry burn	Trajectory corrections - powered		Maneuvering, Pert. rejection TVC / RCS	Reentry burn
Aerodynamic phase	Trajectory corrections - aerodynamics	Hybrid IMU/INS – (D)GNSS- FADS	Maneuvering, Pert. rejection ACS / RCS	Trim control and bank control
Landing burn	Pinpoint landing - powered	Hybrid IMU/INS – (D)GNSS- FADS - altimeter	Maneuvering, Pert. rejection TVC / ACS / RCS	Pitch control Landing burn

Optional

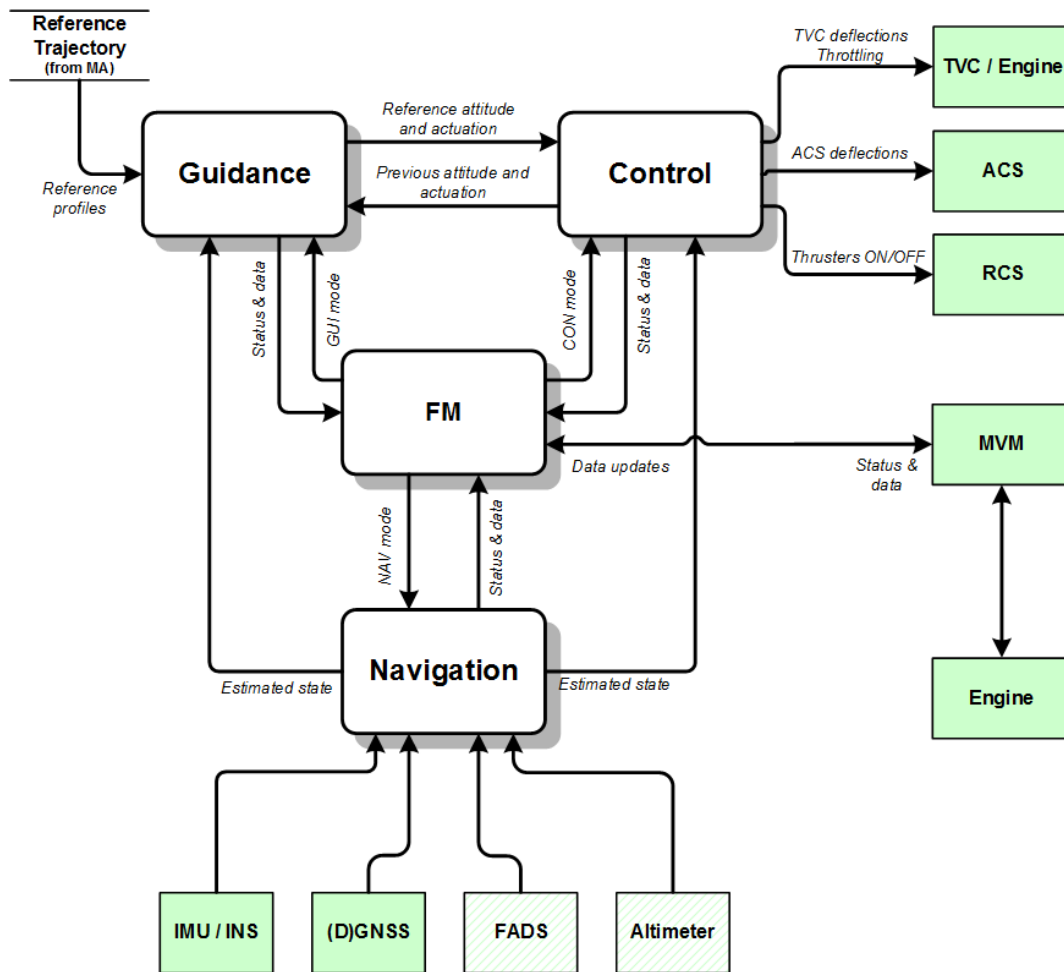

Figure 3: RETALT recovery GNC functional architecture under evaluation

3.2. Guidance

The purpose of the guidance during the return mission is to steer the first stage to the desired landing site, either the launch site or a barge depending on the return scenario, and guarantee a pinpoint landing. The guidance strategy varies for each specific phase of the return mission, due to the different objectives and dynamics encountered for each of the phases, being the powered descent and landing guidance the key algorithm as it shall cope with the fast dynamics of the powered landing phase, where the aerodynamic contribution is still relevant, and shall be robust to the vehicle and environmental uncertainties. As mentioned, the powered descent and landing guidance for the RETALT recovery mission requires sophisticated state-of-the-art algorithms based on online optimization. The strategy is to formulate an optimal control problem, with a dynamic model, constraints, and fuel-optimal objective function, and solve it in real-time. Within this framework, two approaches are identified, which depend on the dynamic and constraint modelling (see Figure 4).

The first approach relies on employing a simple linear model of the vehicle dynamics (e.g. 3-DoF, no aerodynamics, fixed time) and linear state and control constraints. This results in the Optimal Control Problem (OCP) being convex, therefore allowing it to be solved with convex programming techniques, namely second-order cone programming (SOCP) [2]. This is desirable for a real-time implementation since robust convex programming algorithms with convergence guarantees in polynomial time are available. Furthermore, in order to compensate for dispersions arising from the low-fidelity model utilized, the problem may be re-solved periodically with an updated state estimate, thus closing the guidance loop.

On the other hand, more complex nonlinear dynamic models (e.g. 6-DoF dynamics, non-negligible aerodynamics, free time) and constraints may be employed, which result in a higher-fidelity reference

trajectory, but also in a nonlinear and non-convex optimization problem. This requires solving with non-linear programming (NLP) algorithms which is disadvantageous for a real-time implementation, since there is no guarantee of convergence. However, state-of-the-art NLP algorithms for optimal control have been developed in the literature and are better suited than generic algorithms. One example that was developed specifically for powered descent and landing is successive convexification [3], which relies on sequential SOCP optimizations to solve the NLP. Despite this, the time complexity and lack of robustness of this algorithm still prevents it to be utilized with the closed-loop strategy mentioned previously for the convex programming approach, although there is less need of running in closed-loop due to the higher-fidelity of the model.

In RETALT an incremental approach was followed, increasing the complexity of the guidance solution step by step and testing the impact on the trajectory control performance [4]. The final baseline solution includes a complete aerodynamic modelling, variable mass, free time, and variable thrust. It also allows for the implicit satisfaction of operational constraints such as: thrust throttle and attitude magnitude and rate, to consider limitations of the engine and TVC, terminal state, to ensure soft, vertical touchdown, glide slope and aerodynamic angles, to ensure the glidepath remains above a specified limit. To solve this OCP, a successive convexification algorithm was implemented.

The guidance solution is developed focusing mainly on the powered descent and landing phase, but its applicability is tested also for the other phases of the return mission.

3.3. Navigation

To allow the pinpoint landing of the RETALT1 first stage the navigation system shall be able to produce extremely precise estimations of the vehicle states, to give margins to the guidance and control contributions to the GNC error (e.g., position estimation accuracy at landing below 1m, velocity estimation accuracy below 0.2 m/s).

The baseline approach is a Navigation solution for both attitude and translational states, using a coupled system, in which the INS solution is hybridized with the observations provided by the (D)GNSS receiver through an EKF-based filter (Considered Kalman Filter), which considers the effect of parameter uncertainty in the sensor models. No change in mode is required, as the Navigation autonomously and internally manages the applicable process based on periodic or aperiodic availability of measurements from the different sensors (e.g., IMU and (D)GNSS receiver). Figure 5 shows the estimation function architecture. The Navigation is composed of three different sub-functions:

- **Inertial navigation system:** this function pre-processes the IMU measurements which are then inertially propagated yielding rotational state (attitude) and translational state (position and velocity). Gravitational acceleration is estimated based on a J2 gravity model in order to update the velocity and position of the vehicle. This function analytically computes also the state transition matrix needed to propagate the covariance matrix of the state.
- **GPS filter:** this function is activated every time (D)GNSS receiver measurements are available. It receives the navigation estimated state from the INS function, together with the GNSS receiver position and velocity measurements and it compensates the (D)GNSS receiver PVT measurement's delay. Then, the inertial estimated state and the delay-compensated (D)GNSS receiver PVT are passed to a Kalman Filter to improve the estimation of the navigation state. In this latter step both the estimated state and its covariance matrix are updated.
- **Product generation:** this function computes all other output products as co-rotating Cartesian and spherical coordinates, airspeed angles based on the on-board wind tables as well as groundspeed angles. The line fed back from Product Generation to INS is the estimated state at previous step (either updated in the GPS filter function, if (D)GNSS receiver measurements were available, or inertially computed in the INS function, and eventually corrected using the additional sensors measurements).

This navigation solution has the advantage of simplicity and redundancy. In fact, this architecture can be used with any kind of INS and GNSS equipment and allows outage of GNSS measurements, as the two sensors work independently. Other available sensors (altimeter, FADS), could be integrated with an uncoupled architecture.

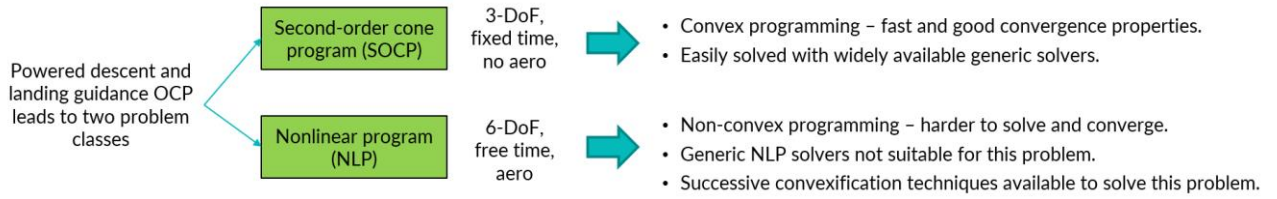

Figure 4: Impact of the OCP formulation on the optimisation algorithm

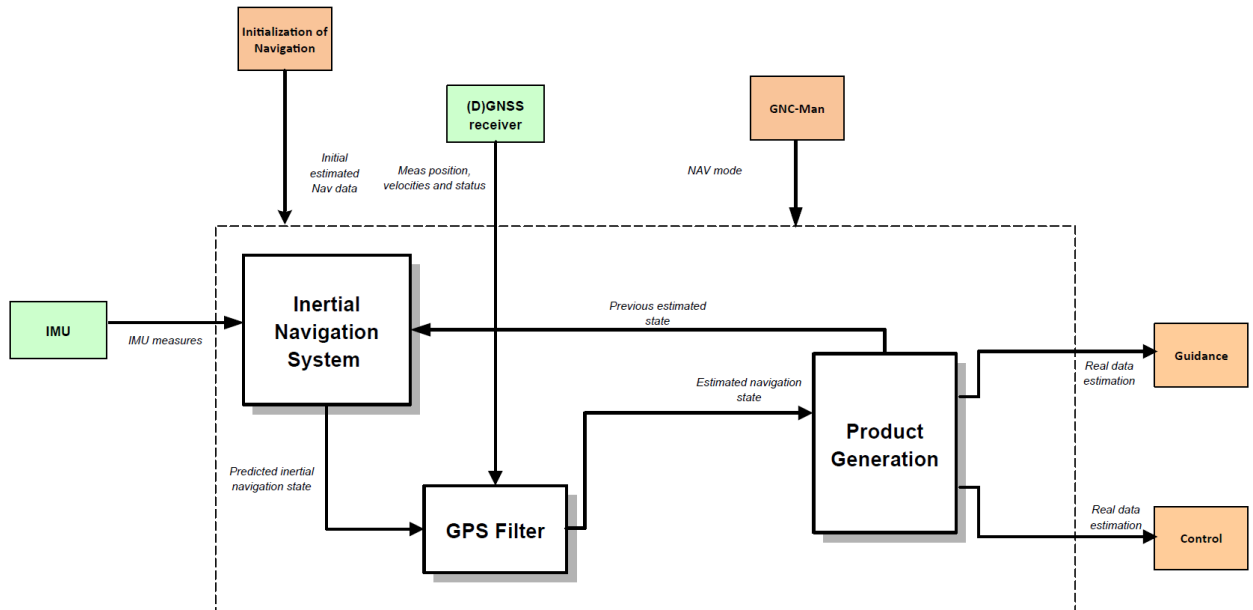

Figure 5: RETALT Navigation functional architecture

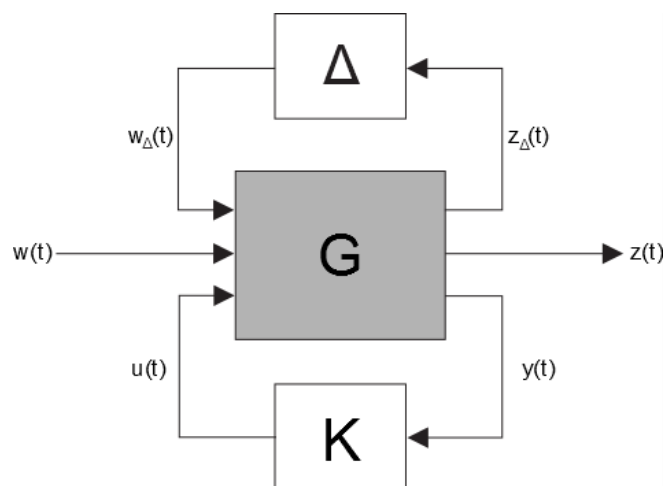

Figure 6: Control synthesis problem

3.4. Control

The objective of the control function is to actuate the vehicle in order to maintain its attitude stable, while rejecting disturbances, and to track the reference attitude as commanded by the guidance, within a given accuracy, as specified by the control requirements. This must be done over the full set of flight conditions while respecting the actuator limitations and constraints.

The control for the recovery of RETALT decouples the control of the pitch and yaw channels exploiting vehicle axis-symmetry through TVC/ACS commands, and controls independently the roll rate control using RCS / ACS.

Multiple MIMO controllers are designed for different points of the trajectory by solving an optimization problem aimed to ensure the closed-loop robustness to model uncertainty and perturbations, following a well structure design methodology which consists in the derivation, at first, of reliable models obtained by using the so-called Linear Fractional Transformation (LFT) framework, which is particularly suitable for robust control design. The LFT framework allows the representation of the system to control by means of the feedback connection of the nominal plant $G(s)$ and a block diagonal uncertainty $\Delta(s)$ gathering all the uncertain parameters of the system. Then, the controller is synthesized using robust control design techniques. The controller synthesis problem (see Figure 6) consists in finding the controller with transfer function $K(s)$ that stabilizes the closed-loop system, while minimizing a given cost function. The structured H_∞ control synthesis [5] was applied in order to obtain a controller which guarantees the robust performance of the closed-loop system in the presence of the uncertainties, while keeping a low order predefined controller structure. Finally, μ -analysis techniques were used to assess the robust stability of the system in presence of dynamical and parametric uncertainties.

4. GNC performance

4.1. Functional Engineering Simulator (FES)

A Functional Engineering Simulator (FES) has been used to support the GNC testing and evaluate the performance of the algorithms developed in RETALT. The RETALT-FES is a high-fidelity simulation environment based on SIMPLAT [6], that has been tailored to RETALT including detailed vehicle configurations and mission scenario models. It allows performing simulations in 3 and 6 DoF, with GNC algorithms in the loop, and performance models of sensors and actuators, see Figure 7. In the FES the G-N-C algorithms have been prototyped and implemented in an integrated GNC solution, that has been tested primarily in the powered descent and landing phase of the DRL scenario. The applicability of the GNC solution designed to other phases of the DRL scenario (i.e. re-entry burn phase, aerodynamic phase) was also preliminarily investigated.

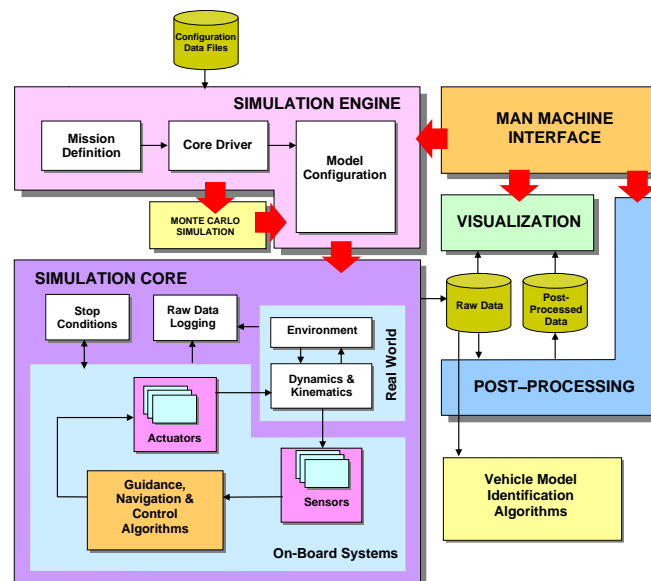

Figure 7: RETALT FES architecture

4.2. Guidance performance

The optimised guidance is able to solve the descent problem guaranteeing good performance in terms of convergence and accuracy of the solution. In the nominal case for the downrange landing scenario, for example, the algorithm converges in less than 15 iterations, with the cost function defined reaching the desired threshold, with the virtual controls used to help the convergence decreasing rapidly below negligible levels, see Figure 8.

The guidance is able to successfully recover uncertainties in initial conditions (in line with the trajectory control capability of the system) environment, aerodynamics and MCI, with very good accuracy at touchdown, as 99.5% of the shots (200 in total) below 15 m of position deviation from the target (including also the contribution of the Control and Navigation to the GNC error), see Figure 9 and Figure 10. The velocity at touchdown is also kept under control, with about 80% of the cases below 3 m/s in terms of horizontal velocity and 99.5% of the cases below 5m/s.

Vertical landing is achieved with the controller being able maintain the verticality of the vehicle, with all the runs showing a final tilt angle less than 5 deg.

Moreover, the propellant needed to complete the phase is less than 10 tons, in line with the propellant budget estimated by mission analysis [7].

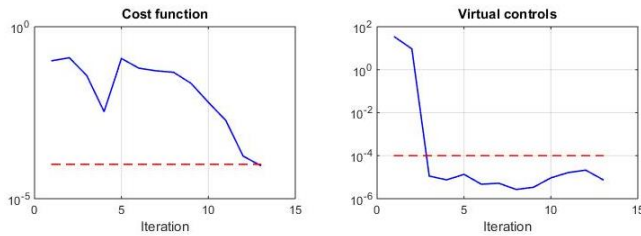

Figure 8: Convergence properties of the guidance solution, nominal case

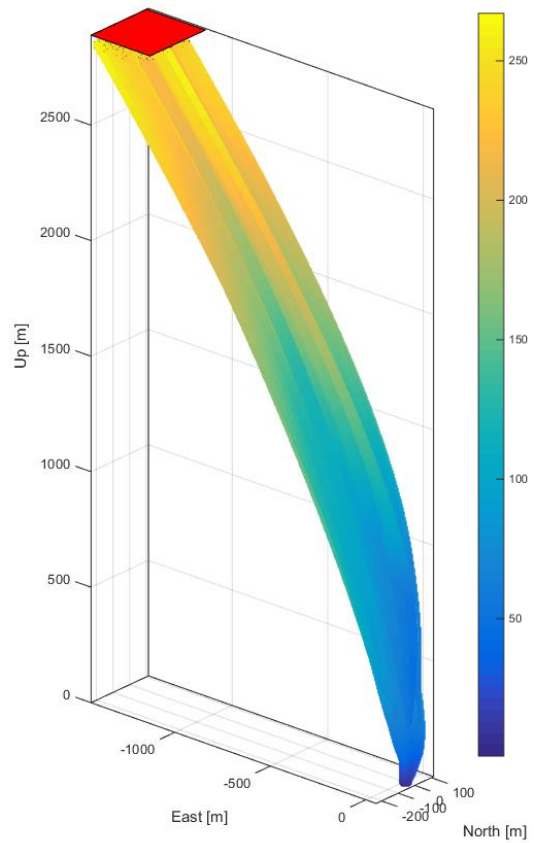

Figure 9: Trajectory path during the powered descent and landing phase

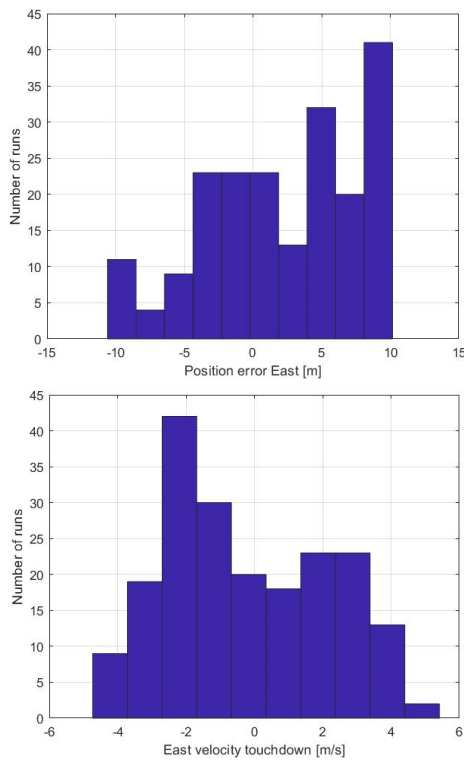

Figure 10: Statistics of position and velocity errors at touchdown

4.3. Navigation performance

A trade-off of the navigation performance allowed the identification of a baseline sensors suite among state of art options: a class II IMU - LN-200E (Northrop Grumman) was used to provide reference performance –, and a differential GNSS, that acts as GNSS when outside the range of D-GNSS operativity. For the latter, the strict requirements of RETALT mission, suggest to limit the selection between the two more precise options (see Figure 12):

- RTK (Real Time Kinematic) positioning, provides the most precise measurements, relative to a local surveyed base station network (ie. Ground station at landing site)
- PPP (Precise Pointing Positioning), which requires provision of real-time GNSS orbit and clock corrections from a dedicated service provider. (ie. using data from the TerraStar correction service to deliver a globally available and reliable solution).

Given the specific nature of the landing problem in RETALT, the RTK method could be beneficial in the RTLS scenario, as the “base” antenna is well known and hence the position of the launcher can be precisely estimated. However, this kind of sensor may not be the most suitable in the case of DRL, if landing has to be performed on a barge. For the DRL on a barge, the preferred option would be to directly use the PPP technology, with the additional advantage of keeping the higher level of accuracy during the whole flight. Both scenarios have been analysed, using as (D)GNSS the Novatel OEM719, configured to be working as RTK or as PPP (TerraStar-C service).

Both allow to reach the desired level of accuracy at landing, being the PPP option more uniform as the performance are independent of the vehicle position, but requiring the acquisition of the TerraStar correction services, while the RTK is depending on the distance to the base antenna, with increasing level of accuracy while approaching it. In general, end-2-end results obtained simulating from MECO until touchdown and considering uncertainties on sensors and navigation performance and mounting showed that the navigation guarantees very good performance, in line with the requirements:

- Position errors < 0.5 m (3σ)
- Velocity errors < 0.2 m/s (3σ)
- Attitude errors < 0.5° (3σ), see Figure 11

The Navigation concept shows very good performance also in presence of winds, when an on-board wind table is used by the navigation. With a wind knowledge error assumed up to 15 m/s, the estimation performance are similar to the no wind case. The winds have a significant impact on the attitude throughout the flight, however the navigation performance are recovering the increased error during the propelled flight phase: roll angle estimation error is within the requirement, while pitch and yaw slightly exceed it. These results shows that the proposed navigation concept is able to provide the required estimation performance, and the use of additional sensors (e.g., (F)ADS) is not strictly necessary, even if their inclusion is not discarded a priori.

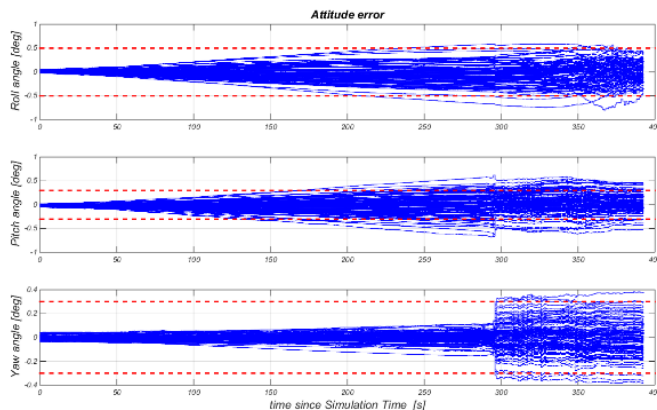

Figure 11: Attitude estimation accuracy, end-2-end return trajectory

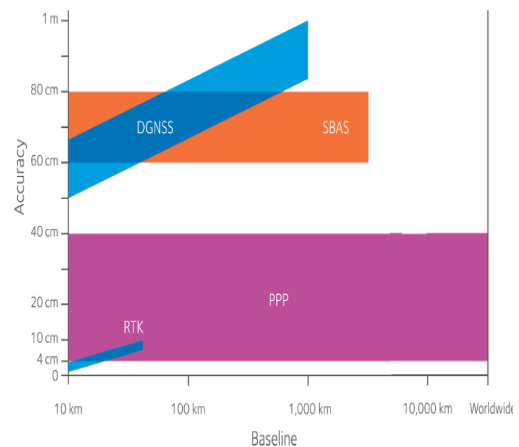

Figure 12: Comparison of GNSS Correction Methods Accuracies

4.4. Control performance

At design level, the performance of the controller are evaluated along the reference trajectory; indeed, given the high variability of the flight conditions for the mission considered, gain-scheduling is applied and the airspeed is used as scheduling variable. In addition, uncertainties in aerodynamics and MCI are considered for the assessment of the robustness properties of the controller. Before performing the synthesis, the control-oriented linear time-invariant models are compared with the FES (in open-loop) to ensure a good validity of the adopted modelling assumptions (see Figure 13), while the achieved closed-loop performance are summarized in Figure 14. The robustness of the designed attitude controller with respect to the considered uncertainties is proved by the mu-analysis, whose results are reported in Figure 15; it can be seen that the upper bound of mu is below 1 for all the operating points, thus confirming robust stability for all the considered flight conditions.

The results with the integrated GNC in the loop confirmed the validity of the Control solution defined, as the vehicle is fully controlled and stable during the complete flight. Moreover, the Control is able to correctly track the maneuvers commanded by the Guidance and required to control the trajectory error. The control error, in fact, is always within 2 deg (the final increase in Figure 16 is due to numerical errors related to the fact that statistics are computed w.r.t. time and not all the simulations considered have the same duration).

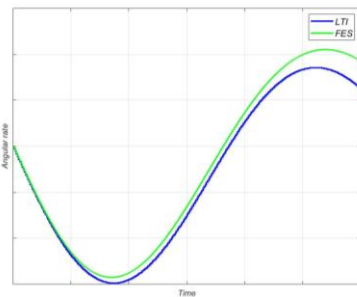

Figure 13: FES and LTI models comparison of open-loop response to a step of fin deflection at a specific operating point

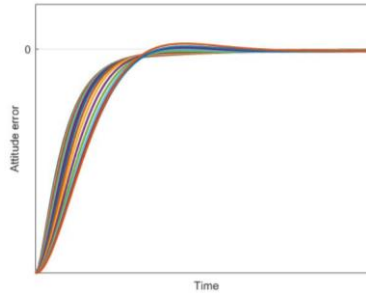

Figure 14: Pitch attitude controller time domain performance for different flight speeds; step response time history

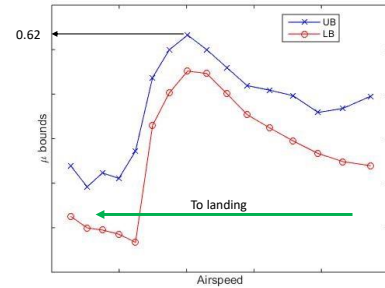

Figure 15: Structured singular value behaviour along trajectory

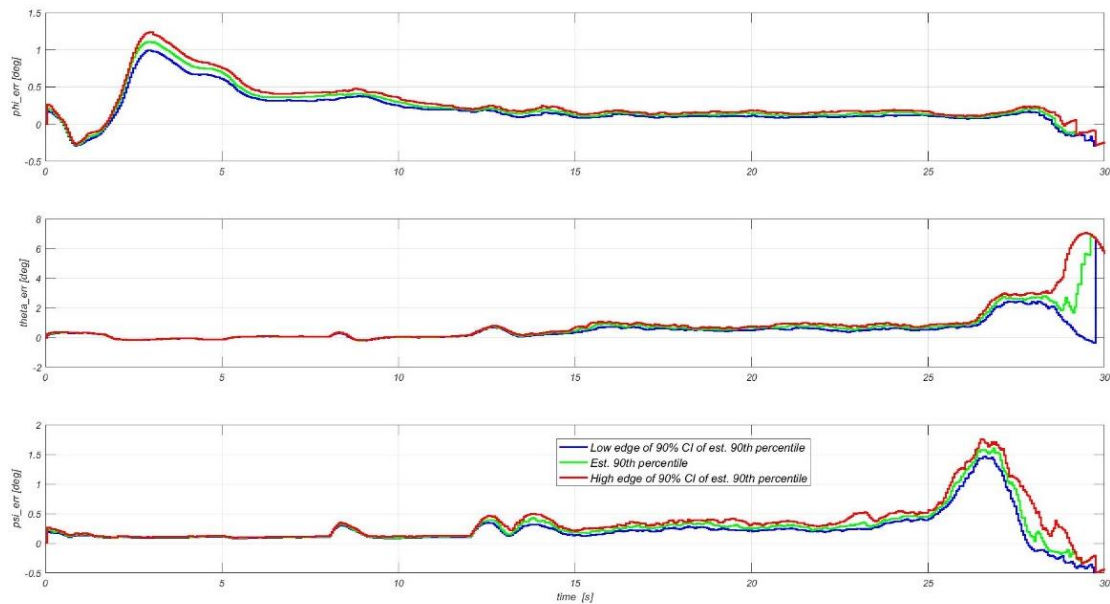

Figure 16: Attitude control errors during the powered descent and landing phase (90% range and 90% confidence intervals)

5. Conclusions

In the framework of RETALT a recovery GNC solution was defined to address the problem of steering the first stage of RETALT1 to the desired landing area, enabling therefore the recovery and thus the reusability of the booster. An end-2-end GNC architecture was defined, and critical algorithms were prototyped to assure a precise estimation of the vehicles state and the capability to perform pinpoint landing while recovering relevant uncertainties and with a fully controlled vehicle. The GNC solution relies on state-of-art sensors, and makes use of RCS, TVC, and ACS, depending on their availability during the return flight.

A high-fidelity functional engineering simulator framework was used to integrate the complex vehicle's models and the GNC algorithms, allowing the test of the proposed solution in a model-in-the-loop simulation environment.

The results of the simulation campaigns show good GNC functioning and promising performance. The main test campaigns focused on the powered descent and landing phase, that is the most critical part of the flight. For this phase, the proposed GNC solutions reached a TRL of 3. Further tuning and small improvements are necessary to be fully compliant with all the requirements, but the results obtained indicate that the solution proposed is valid.

Further development of the GNC shall focus on the consolidation of the end-2-end GNC solution for the complete return phase, including the management of the boost-back burn and the re-entry burn, for which preliminary tests were carried out but a fully integrated and coherent GNC solution is not yet fully consolidated. In particular, the focus should be the testing of the optimised guidance, as the hybrid navigation has been assessed for the complete return scenario, and the control synthesis also covered all phases of the return trajectory.

Acknowledgements

This project has received funding from the European Union Horizon 2020 research and innovation programme under grant agreement No 821890.

The authors thank DLR, the coordinator of RETALT, and all the partners (ALMATECH, Amorim, CFS Engineering, and MT Aerospace) for the hard work and fruitful collaboration during the project.

References

1. Marwege A. et al (2019) "Retro Propulsion Assisted Landing Technologies (RETALT): Current Status and Outlook of the EU Funded Project on Reusable Launch Vehicles", 70th IAC, Washington D.C., United States
2. Acikmese, Behcet, and Scott R. Ploen. "Convex programming approach to powered descent guidance for mars landing." *Journal of Guidance, Control, and Dynamics* 30.5 (2007): 1353-1366.
3. Szmuk, Michael, Behcet Acikmese, and Andrew W. Berning. "Successive convexification for fuel-optimal powered landing with aerodynamic drag and non-convex constraints." *AIAA Guidance, Navigation, and Control Conference*. 2016.
4. Botelho A., et al, "Design of the landing guidance for the retro-propulsive vertical landing of a reusable rocket stage", CEAS Space Journal, DOI: 10.1007/s12567-022-00423-6 (2022).
5. Mathworks. Control Design Toolbox. Online, retrieved May 2022. URL: <https://it.mathworks.com/help/control/>.
6. Fernandez, V., et al. The IXV GNC Functional Engineering Simulator. 11th SESP Workshop, Noordwijk, The Netherlands, (2010).
7. De Zaiacomio G., et al, "Mission engineering for the RETALT VTVL Launcher", CEAS Space Journal, DOI: 10.1007/s12567-021-00415-y (2022)